



General Chemistry Laboratory

Chromatography





Preparation

Collect the following items From your personal equipment

- Mortar and pestle
- Glass column
- Rubber stopper
- Plastic dropper
- Dropper (229 mm)
- Capillary tubes for TLC
- TLC plate
- Aluminum foil
- UV light (shared)
- Green leaves
- 30 and 100 mL beaker
- 50 and 125 mL Erlenmeyer flask
- Twenty test tubes and test tube rack
- Glass rod
- Funnel
- Tweezers





Objective and Principles

- **Objective:** To separate and identify mixtures using column chromatography (CC) and thin-layer chromatography (TLC)
- **Principle:** Base on the different distribution of compounds between a stationary phase and a mobile phase
- **Lab techniques:**
 - Extraction
 - Column chromatography
 - Thin layer chromatography



Step 1: Extraction



- Cut about 1 g of green leaves to pieces
- Grind with 10 mL hexane/ethyl acetate (8 : 2, v/v) solvent
- Use dropper to transfer the extract into a graduated cylinder as the sample solution; the amount of extract solution is about 2 mL

- ✓ Choose leaves which is dark green and soft
- ✓ During grinding, the extraction solvent may evaporate. More solvent could be added



Step 2: Prepare Silica Gel Slurry

- Prepare 60 mL hexane/acetone (7 : 3, v/v) eluent
- Take 20 mL eluent to a beaker
- Weigh 4 g of silica gel and add it to the beaker with stirring
- Stir the mixture with a glass rod thoroughly to free the gas bubbles

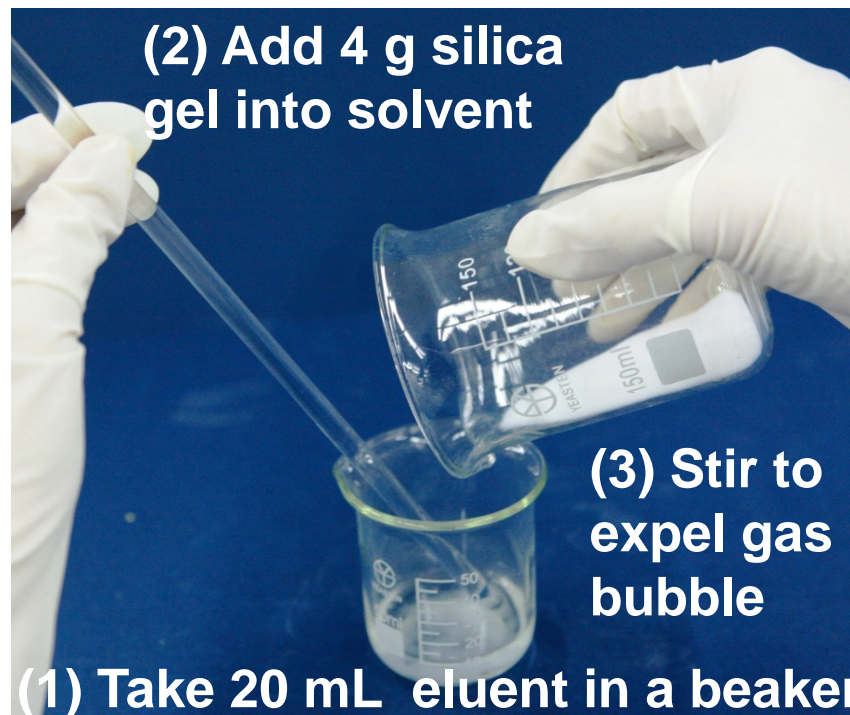



Step 3: Column Packing

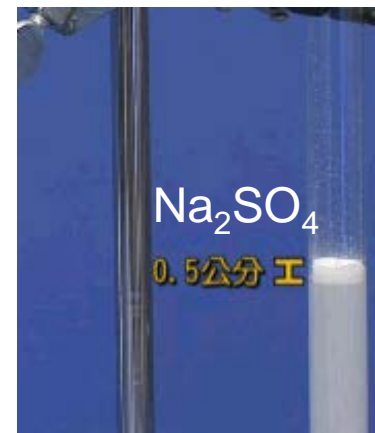
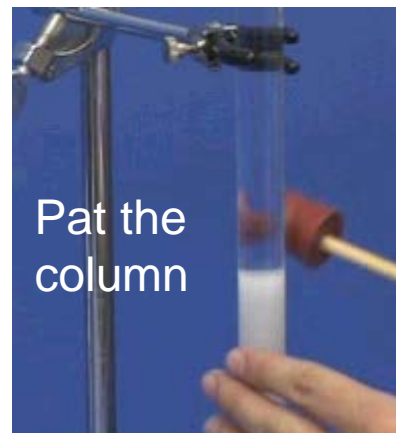
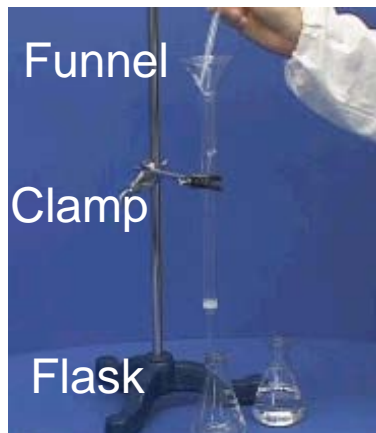

- Use a rubber stopper plugged with a wooden stick or pen as a tool for patting
- Fix the glass column upright on the support stand with a three prong clamp
- Place a Erlenmeyer flask under the column to receive the eluent
- Add 5 mL of eluent through the funnel to drive out bubbles in the glass frit
- Stir silica gel slurry evenly with a glass rod and quickly poured into the column
- Rinse off the remnant in the beaker by some eluent with a dropper
- Pat the column often to remove air bubbles and make the packing even and tight
- Add a layer of Na_2SO_4 of 0.5 cm thickness at the top when the eluent reaches the top of the silica gel
- Add more eluent if needed



Step 4: Loading Sample and Elution

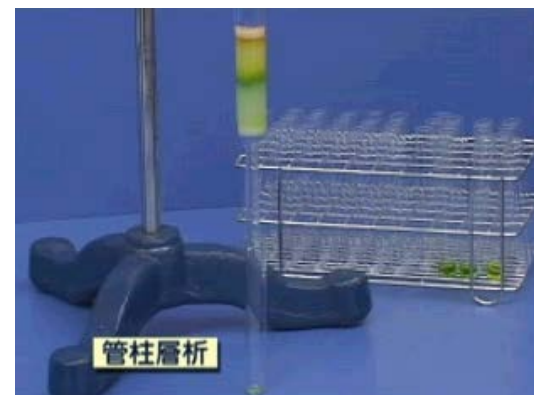

Apply sample

- Let the surface of the eluent reaches the top of the stationary phase
- Apply the sample solution circularly with a dropper to the top of stationary phase to form a small layer

Rinse

- Let sample solution submerge into the surface of the silica gel completely
- Draw small amount of eluent to wash down the sample adhered on the wall of the column

Elute and collect

- Continue adding eluent to start the chromatography
- Collect the eluent in the test tubes. Switch the test tube every 1 mL

✓ Pay attention to refill the column so that the eluent does not drop below the surface of the silica gel. This will cause cracks in the column.



Step 5: Prepare Sample for TLC

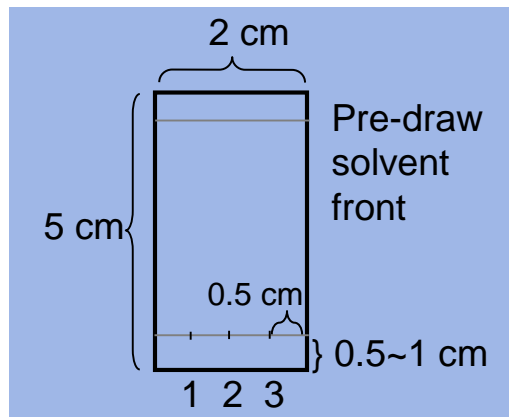
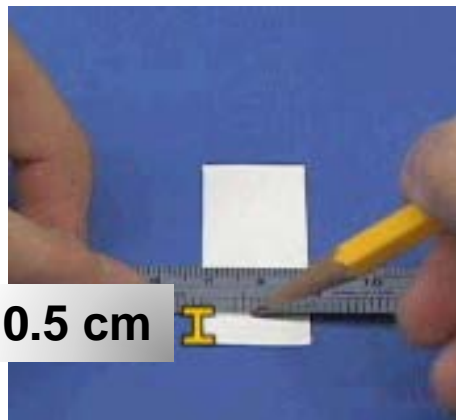

- Draw a line at a position about 0.5 cm above the bottom of the TLC plate with a pencil
- Draw a short vertical line over the starting line every 0.5 cm as starting position for the sample
- Fill the capillary tube with the original extract (r) and touch to the TLC plate gently and briefly
- Place two spots of the fractions to the plate using another capillary tube
- Add developing solvent (hexane/acetone = 7 : 3) to a 30 mL beaker to 0.2 cm high
- Cut out a strip of filter paper and place it against the wall of the beaker
- Cover the beaker with aluminum foil to reach liquid-vapor equilibrium

✓ If concentration of the fraction is too low, allow spot to evaporate and repeatedly spot at the same place to increase the loading



Step 6: Developing and Recording of TLC

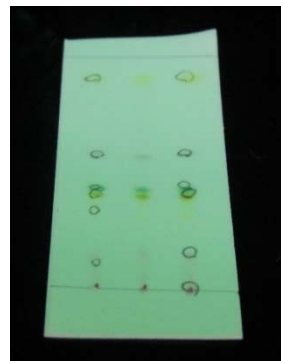

- Place the TLC plate into the developing chamber with the tweezers
- Let the top end lean against the wall so that the plate stand in the chamber, and do not touch the wall or filter paper on both sides so as not to affect the climbing of eluent
- Check the height of the spots should be higher than the surface level of the developing solvent
- Cover the beaker with aluminum foil and allow the solvent to advance up

- Take the TLC plate out when the solvent front reaches pre-draw line
- Mark the position of each spot with a pencil, calculate and record the R_f value of each spot, and record the eluent used
- You may observe the separation of TLC under UV light

$$R_f = \frac{\text{distance traveled by the compound}}{\text{distance traveled by the eluent}}$$



Additional Notice

- Put on the disposable mask to avoid inhalation of small particulates of silica gel
- Apply the eluent constantly to avoid the level of eluent lower than the stationary phase that may lead to cracking of stationary phase
- The capillary tube should be touched to the TLC plate very briefly and gently while spotting
- Touch the used capillary tube to paper towel to draw the sample out, then rinse with clean solvent several times to reuse it
- Reverse the column to drain the adsorbent and apply pressure to force the solid out of column after experiment



Clean-Up and Check-Out

- Discard the organic waste, TLC plates, capillary tubes, and silica gel to the designated waste bins
- Clean up the lab bench and check personal equipment inventory (have an associate TA signed the check list)
- This is a **Brief Report** experiment:
 - Hand in prelab/lab note/report together to the TA
- Groups on duty shall stay and help clean up the lab





Column Chromatography

- Prepare silica gel slurry with stirring to free air bubbles
- Add portions of eluent to free the gas in fritted glass of column
- Gently tap the column while filling the column to free any trapped air bubbles and pack the column more tightly and uniformly
- Add a layer of Na_2SO_4 of 0.5 cm thickness at the top when the eluent reaches the top of the silica gel
- Apply the sample when the surface of the eluent reaches the top of the stationary phase
- The sample should be introduced uniformly and symmetrically, without disturbing the column sorbent
- Apply the eluent constantly to avoid the level of eluent lower than the stationary phase that may lead to cracking of stationary phase



Thin-Layer Chromatography

- The sample should be diluted with the solvent before spotting to avoid tailing
- Spotting should be carried out with a capillary tube with diameter smaller than 1 mm to control the sample spot to within a diameter of 2 mm
- Draw the line and spot the sample gently to avoid damaging the plate
- Place the plate into the developing chamber with the tweezers, set it in the center of the chamber, and avoid touching the sides
- The starting line should be higher than the surface level of the eluent to prevent the sample from dissolving in it
- Cover the beaker with aluminum foil to reach liquid-vapor equilibrium
- Take the plate out when the solvent front is 0.5 to 1.0 cm from the top of the plate
- Mark the solvent front immediately with pencil after developing
- Do not shine the UV light directly on skin or eyes while observing the sample points